

Strainer series **FA** Strainer – air separator series **FDA**



www.isoilmeter.com



Strainer series FA Strainer - air separator serie FDA

FDA series of strainer - air separator are fundamental, for metering groups, as long as they perform the important task of protection against solid particles carried by the fluid and remove air or gas present in the liquid. This two factors may influence the measuring accuracy. Putting together in a single device filtering and air elimination, results in a more compact device reducing the size of the group.

In specific applications in which only filtration is required, i.e. when viscosity of the fluid is higher than 20 mPa.s @20°C, the **FA** series of strainer is available. The large filtering surface, in relation to the input /output section ratio of the fluid, means low pressure loss and the mean time between net cleaning becomes really long.

The choice of the basket strainer must take into consideration the characteristics of the fluid. We suggest 100 mesh for gasoline, 60 mesh for diesel fuel and 40 mesh for fuel oil.

Technical characteristics

Designed to comply with directive 97/23/CE PED and 94/9/CE ATEX.

Material of construction: Carbon steel

Air vent valve: incorporated in the upper part of the cover to let the vapour get out the vessel.

Filtering basket in stainless steel AISI 304.

The flow direction from outside to inside the basket allows the removal of the impurity while draining the device.

Working temperature: -30; +100 °C

Maximum working pressure: 10 bar

Flanges: ANSI 150 RF

Maximum Pressure loss (with clean basket at max. flow rate): 2 kPa for refined products, 6 kPa for high viscosity products.

Maximum differential pressure: (admitted with a dirty basket): 150 kPa.

Painting: only external parts, with two component epoxy paint, hydrocarbon resistant.

Air vent valve (only for FDA)

Materials:

- » body: aluminium
- » piston: anodized aluminium
- » floating ball: stainless steel
- » gaskets: FKM
- » pivots (on aluminium levers): stainless steel
- » threaded connection for air eliminator Ø1" NPT female

Accessories

- » thermal relief valve
- » sectioning ball vales (upstream and downstream)
- » differential pressure gauge with local indicator or with electrical switch ATEX approved, for automation interlock
- » line pressure gauge
- » 1" 1/4 NPT, drain valve
- » 1" Gas, vent valve

On request

- » piston (air vent valve): stainless steel
- » painting of internal parts with Epoxy paint
- » pressure > 10 bar
- » construction in stainless steel

Characteristics of basket strainer

Mesh per inch	Net span (mm)	Useful path%
40	0,437	50,8
60	0,307	52,6
100	0,153	36,2



Strainer Air separator Type	Strainer Type	Filtering surface gross cm ²	Flanges input/output	Maximum flow rate m ³ /h
FDA 200	FA 200	1570	3" o 4"	150
FDA 400	FA 400	4200	3", 4" o 6"	210
FDA 600	FA 600	5470	4", 6" o 8"	270
FDA 1000	FA 1000	7800	6", 8" o 10"	390
FDA 3000	FA 3000	13000	8" o 10"	942



Strainer series FA

Strainer - air separator series FDA

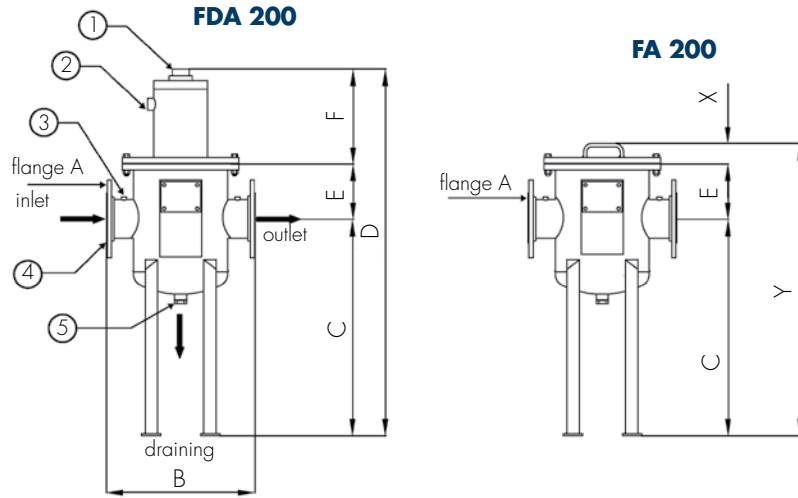

Type	A	B	C	D	E	F	X	Y
FA/FDA 200	3" ANSI 150	480	650	1170	165	362	103	918

- 1) Draining strainer DN 1" NPT-F
- 2) Differential pressure gauge DN 1/2" NPT-F
- 3) Differential pressure gauge DN 3/8" NPT-F
- 4) Inlet-outlet flange
- 5) Draining DN 1" 1/4 NPT-F

FDA 400-600-1000-3000

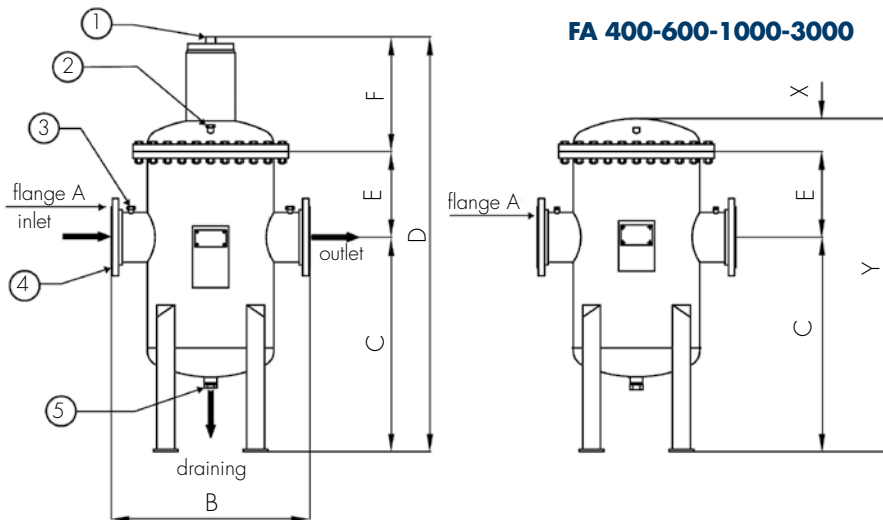

Type	A	B	C	D	E	F	X	Y
FA/FDA 400	4" ANSI 150	760	750	1405	200	455	174	1124
FA/FDA 600	6" ANSI 150	880	750	1485	260	475	187	1197
FA/FDA 1000	8" ANSI 150	880	950	1837	380	507	210	1540
FA/FDA 3000	10" ANSI 150	1000	950	1875	400	531	250	1600

Dimensions in millimeters



ISOIL IMPIANTI
The solutions that count

Isoil Impianti spa - Italy
24061 Albano S. Alessandro (Bg)
 74, via Madonna delle Rose
 Phone +39 035 4239.011
 Fax +39 035 582078
 sales@isoil-impianti.it
 www.isoilmeter.com

Isoil Impianti spa - Italy
 Sales offices
20092 Cinisello Balsamo (Mi)
 27, via F.lli Gracchi
 Phone +39 02 91988.5
 Fax +39 02 66012457

Isoil Impianti spa
 China Representative Office
 Rm 2203. China Garments Mansion
 99 Jianguo Road. Chaoyang District
100020. Beijing. P.R. China
 Phone +86 10 6581 1618
 Fax +86 10 6581 1618
 china@isoilmeter.com